

SMOKE ALARM INSTRUCTION

WELCOME USING LX108 SMOKE ALARM

The product adopts ionization room with advanced single-power twin-room structure in the world, 9V battery as power source, and economizes electricity. It is used in single room in family. For your safety, you'd better install one alarm in every room. Please read the instruction carefully before you use it, do not open the alarm easily to avoid being irregular for working. You cannot replace any component in this product except for battery to avoid irregular working, if there is any wrong with it, please contact the supplier promptly.

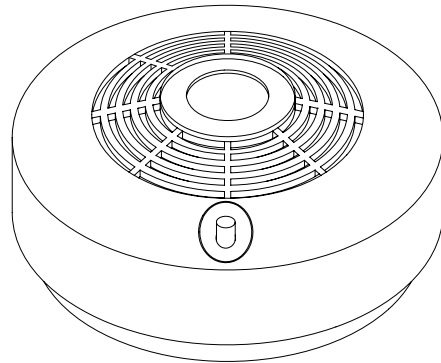

FUNCTION:

- The ionization room adopts single-power twin-room structure in the world, has high sensitivity and good anti-jamming performance,
- Adopts special control CMOS chip gathering high compositive degree, steady performance and long using life;
- Tiny power consumption, battery as power source, safety, convenient installation, not join other power source,
- Alarm function of low voltage, reminding you to replace the battery on time;
- Periodic testing: We suggest that you'd better do a simulation testing every week or every 15 days to guarantee your damage declining to the lowest when danger happen, you only press the testing button gently for this work;
- Convenient installation: Do not effect by the position of power, spare the trouble of drawing power source, please refer to "installation way and note" for the installation;
- Double alarm: Adopts double alarm of sound-audio, it can attend the common or lower audition user at the same time.

SPECIFICATION:

Power source: DC9V (cascading battery power)

Working current:: surveillant current <10uA,
alarm current <10mA;

Alarm sound: >85dB

Ambient temperature: -10℃~50℃

Ambient humidity: ≤95%(40±2℃)

INSTALLATION AND NOTE:

- After tryout for the detector, please replace the battery one time every year, otherwise, it will effect the working because of the low voltage of battery;
- There is no component to replace by yourself except for battery in detector, if there is any wrong with the product, please contact our service department;
- Do not place it at the high humidity, dusty position;
- You should install it after the room is decorated; it should be placed in dustproof, moistureproof, mildewproof position;
- The detector should be installed 1.5m away from the blast mouth of air conditioner, there is no hinder 0.5m in front of detector;
- The detector is suitable for level installation, if you want to install slantways, the degree is less than 45;
- Having a test for the detector termly. When testing, please press the testing button, the buzzer in the detector will chime within 10sec; output the testing signal at the same time and collect the alarm to emit alarm of sound-audio;
- If the detector sound one time every minute, please replace the battery promptly. The battery should be 9V cascading.

INSTALLATION AND TESTING:

- The distance between installation holes on the base is 80mm; fix two wooden bolts ($\Phi 3 \times 12$) on the selected position, then push the detector.
- It will be sound-audio alarm when electrifying alarm first, stop alarming within 10sec, then press the testing button after 60sec, if the alarm is sound-audio alarm, it can be used, if it do not alarm or stop alarming, please contact the supplier .Do not open your alarm by yourself.

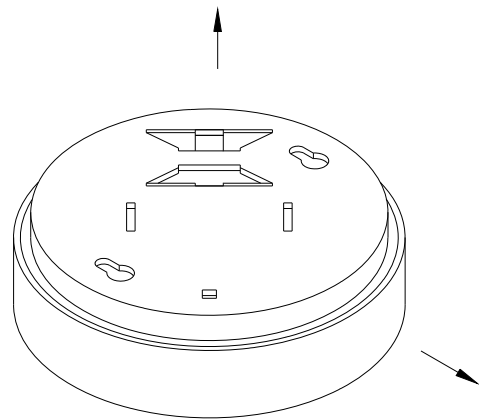

NOTE:

The smoke alarm cannot be substitute for fire alarm system; it is not sensitive to flammable gas. We must state that smoke is not secure substitute, at any time it might be failure; so you must test it periodically and replace it every 5 years. Once there is accident, we do not undertake any responsibility.